

## A20 Planfräser *Face mills, Fraises à surfacer, Frese a spianare*

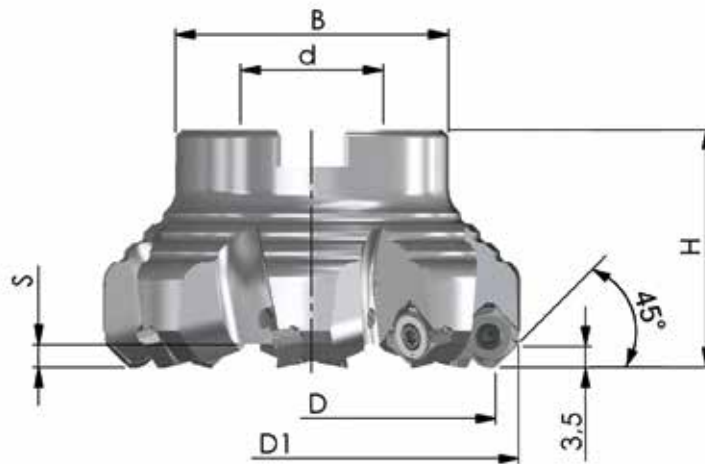

### Aufsteckfräser *Shell type mills, Fraises à alésage, Frese per attacco a manicotto*



Bestell-Nr. <i>Order-No., Référence, Codice</i>	D	D <sub>1</sub>	H	d	B	S	Z	MS
45PP-040-A20-5	40	48	40	16	38	4,0	5	MS-8x25-912
45PP-050-A20-5	50	58	40	22	46	4,0	5	MS-10x25-912
45PP-063-A20-6	63	71	40	22	46	4,0	6	MS-10x25-912
45PP-080-A20-7	80	88	50	27	58	4,0	7	MS-12x30-912
45PP-100-A20-9	100	108	50	32	78	4,0	9	MS-16x30-912
45PP-125-A20-10	125	133	63	40	90	4,0	10	MS-20x55-7991
<b>Enge Teilung</b> <i>close pitch, à pas réduit, a passo stretto:</i>								
45PP-040-A20-6	40	48	40	16	38	4,0	6	MS-8x25-912
45PP-050-A20-7	50	58	40	22	46	4,0	7	MS-10x25-912
45PP-063-A20-8	63	71	40	22	46	4,0	8	MS-10x25-912
45PP-080-A20-9	80	88	50	27	58	4,0	9	MS-12x30-912
45PP-100-A20-11	100	108	50	32	78	4,0	11	MS-16x30-912
45PP-125-A20-12	125	133	63	40	90	4,0	12	MS-20x55-7991

## A20 Planfräser *Face mills, Fraises à surfacer, Frese a spianare*



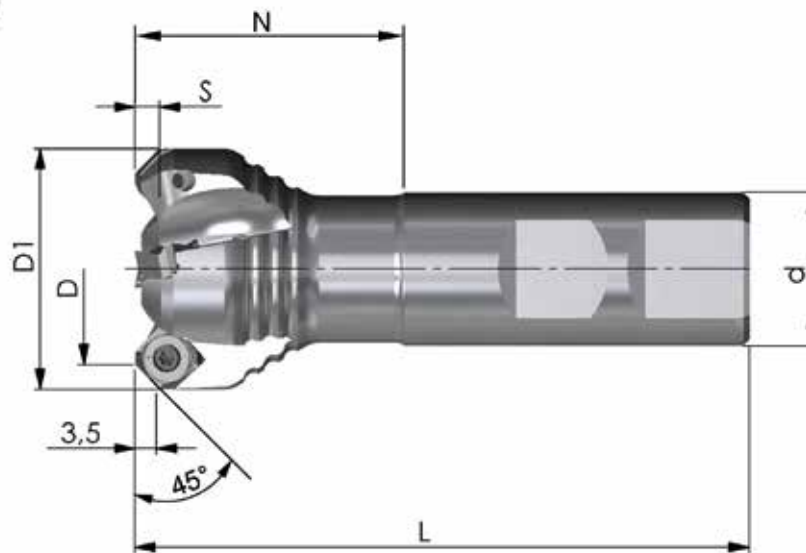





Schafffräser DIN 1835-B *Shank type mills, Fraises à queue Weldon, Frese a gambo Weldon*



Bestell-Nr. Order-No., Référence, Codice	D	D <sub>1</sub>	N	L	d	S	Z
45PP-20-20-A20-2	20	28	50	100	20	4,0	2
45PP-25-25-A20-3	25	33	44	100	25	4,0	3
45PP-32-25-A20-4	32	40	44	100	25	4,0	4

## A20 Fräswendeplatten und Schnittdaten

Milling inserts and parameters, Plaquettes de fraisage et paramètres, Inserti e parametri di taglio

			HC45 (code 41)	HC30 (code 52)	XC35 (code 46)	HC20 (code 53)			
	<b>JMA20-534-</b> IK 9,0 x 4,48 R0,6	Order- No.	<b>A20A-WD41</b>	<b>A20A-UC52</b>		<b>A20A-TB53</b>			
	<b>H M</b> 	$f_z$ [mm]	0,20 (0,10-0,30)	0,20 (0,10-0,30)		0,30 (0,10-0,50)			
	<b>JMA20-834-</b> IK 9,0 x 4,48 R0,6	Order- No.	<b>A20B-YD41</b>		<b>A20B-AE46</b>	<b>A20B-XC53</b>			
	<b>M S</b> 	$f_z$ [mm]	0,20 (0,10-0,30)		0,20 (0,10-0,30)	0,30 (0,10-0,50)			
			20	20	20	20			
									
	<b>JMA20-834B-</b> IK 9,0 x 4,48 R0,6	Order- No.				<b>A20B-BF53</b>			
	<b>U</b> 	$f_n$ [mm/U]				2,00 (1,00-3,00)			
						10			

$V_c$ [m/min]	Stahl Steel Acier Acciaio	Rostfrei Stainless Acier inoxydable Inossidabile	Guss Cast iron Fonte Ghisa	NE-Metalle Non-ferrous metals Non ferreux Metalli non ferritici	Hochwarmfest Highly heat-resistant Superalliages Resistente al calore	Gehärtet Tempered Aciers traités Temprato
<b>HC45</b>	250 (200 - 350)	240 (140 - 300)	240 (130 - 280)			
<b>HC30</b>	160 (120 - 220)	200 (100 - 300)			60 (40 - 200)	
<b>XC35</b>	160 (120 - 220)	200 (100 - 300)			60 (40 - 200)	
<b>HC20</b>			260 (180 - 350)			80 (40 - 120)

### Ersatzteile Spare parts, Pièces de rechange, Parti di ricambio

	<b>SS 3,0-2</b> (M = 1,7-1,8 Nm)		<b>T 09</b>		<b>Fett</b> Grease, Graisse, Grasso
---	-------------------------------------	---	-------------	---	--

## **A20** Montageanleitung Breitschichtplatte *Assembly instruction wiper insert,* *Instruction de montage de la plaquette racleuse, Istruzioni d'impiego per il montaggio dell' inserto raschiante*

