

B29 Eckfräser 90° *Step mills, Fraises à 90°, Frese per spallamenti retti*

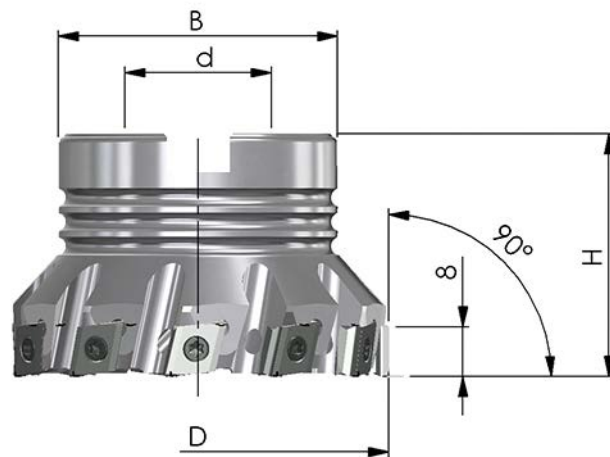

Aufsteckfräser *Shell type mills, Fraises à alésage, Frese per attacco a manicotto*



Bestell-Nr. <i>Order-No., Référence, Codice</i>	D	H	d	B	Z	MS
90PP-032-B29-4	32	40	16	30	4	MS-8x25-912
90PP-040-B29-5	40	40	16	38	5	MS-8x25-912
90PP-050-B29-6	50	40	22	46	6	MS-10x25-912
90PP-063-B29-8	63	40	22	46	8	MS-10x25-912
90PP-080-B29-10	80	50	27	58	10	MS-12x35-912
Enge Teilung <i>close pitch, à pas réduit, a passo stretto:</i>						
90PP-032-B29-5	32	40	16	30	5	MS-8x25-912
90PP-040-B29-6	40	40	16	38	6	MS-8x25-912
90PP-050-B29-8	50	40	22	46	8	MS-10x25-912
90PP-063-B29-11	63	40	22	46	11	MS-10x25-912
90PP-080-B29-13	80	50	27	58	13	MS-12x35-912

MS= Mittenschraube *Central screw, Vis centrale, Vite centrale di fissaggio*

B29 Eckfräser 90° *Step mills, Fraises à 90°, Frese per spallamenti retti*



Schaftfräser DIN 1835-B *Shank type mills, Fraises à queue Weldon, Frese a gambo Weldon*

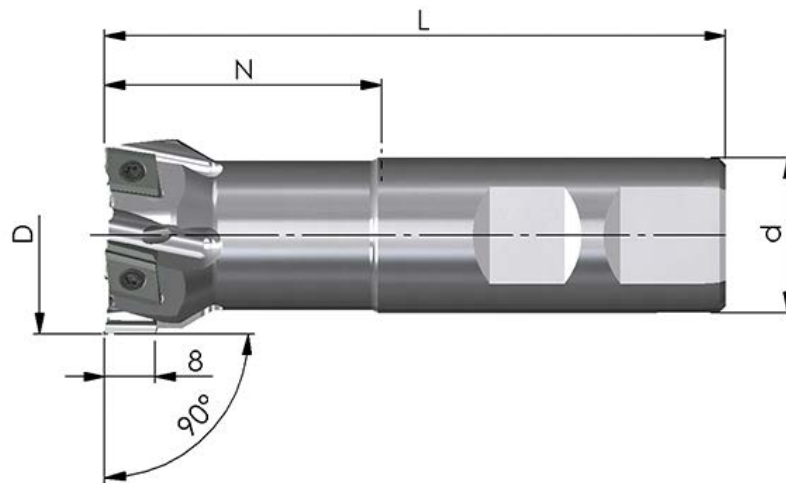

Bestell-Nr. <i>Order-No., Référence, Codice</i>	D	N	L	d	Z
90PP-25-44-25-B29-3	25	44	100	25	3
90PP-32-44-25-B29-4	32	44	100	25	4
90PP-32-44-32-B29-4	32	44	104	32	4
90PP-40-44-32-B29-5	40	44	104	32	5

B29 Vielzahnfräser

Multi-Tooth milling cutters, Fraises multi-dents (hérisson),
Frese a riccio





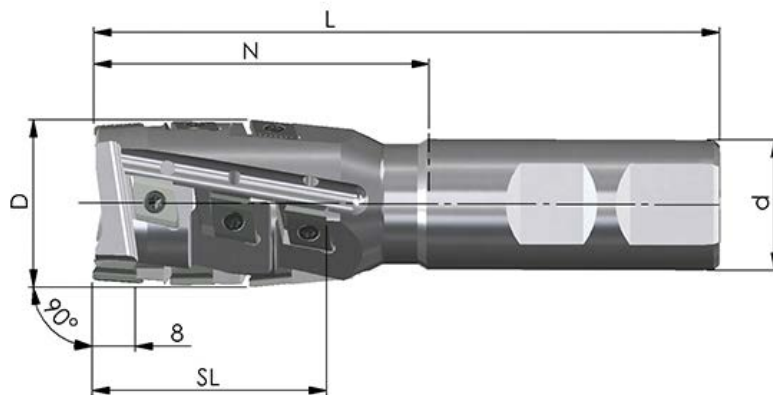







Schaftfräser DIN 1835-B Shank type mills, Fraises à queue Weldon, Frese a gambo Weldon

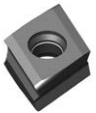

Bestell-Nr. <i>Order-No., Référence, Codice</i>	D	SL	N	L	d	Z _{eff.}	ZZ
VZF-25-44-25-B29-2	25	45	63	120	25	2	12
VZF-28-44-25-B29-2	28	45	63	120	25	2	12
VZF-32-44-25-B29-2	32	45	63	120	25	2	12
VZF-32-44-32-B29-2	32	45	59	120	32	2	12
VZF-40-44-32-B29-3	40	45	59	120	32	3	18

B29 Fräswendeplatten und Schnittdaten

Milling inserts and parameters, Plaquettes de fraiseage et paramètres, Inserti e parametri di taglio

			HC45 (code 41)	HC30 (code 52)	HC35 (code 50)	XC35 (code 46)	XC34 (code 64)	HC20 (code 53)	K15M (code 8)
	JMB29-T08PR06- IK 8,0x4,0 R0,6 + Fase*	Order- No.	B29TZ -41-A	B29YL -52-A				B29WA -53-A	
		f _z [mm]	0,15 (0,05-0,25)	0,15 (0,05-0,25)				0,15 (0,05-0,25)	
	JMB29-T08GR06- IK 8,0x4,0 R0,6	Order- No.	B29AX -41-B		B29SM -50-B	B29KZ -46-B	B29ES -64-B	B29YU -53-B²⁾	
		f _z [mm]	0,15 (0,05-0,25)		0,15 (0,05-0,25)	0,15 (0,05-0,25)	0,15 (0,05-0,25)	0,15 (0,05-0,25)	
	JMB29-T08GR02- IK 8,0x4,0 R0,2	Order- No.							B29RW -08-B
		f _z [mm]							0,20 (0,15-0,25)
			20	20	20	20	20	20	20

* Fase, chamfer, avec chanfrein, smusso

V _c [m/min]	Stahl Steel Acier Acciaio	Rostfrei Stainless Acier inoxydable Inossidabile	Guss Cast iron Fonte Ghisa	NE-Metalle Non-ferrous metals Non ferreux Metalli non ferrosi	Hochwarmfest Highly heat-resistant Superalliages Resistente al calore	Gehärtet Tempered Aciers traités Temprato
HC45	250 (200 - 350)	240 (140 - 300)	240 (130 - 280)			
HC30	160 (120-220)	200 (100 - 300)			60 (40 - 200)	
HC35	220 (200 - 350)	160 (100 - 300)			60 (40 - 200)	
XC35	120 (60 - 160)	100 (60 - 180)			80 (40 - 200)	
XC34		100 (60 - 180)			80 (40 - 200)	
HC20			260 (180 - 350)			80 (40 - 120)
K15M				400 (300 - 600)		

Ersatzteile Spare parts, Pièces de rechange, Parti di ricambio

	SS 3,0-2 (M = 1,7-1,8 Nm)		T 09		Fett Grease, Graisse, Grasso
---	-------------------------------------	---	-------------	---	--